

SCHEDA TECNICA

CAMERETTA 100X100 INTERNO 122X122 ESTERNO H 100

POZZETTI IN CEMENTO VIBRATO



NORMA DI RIFERIMENTO UNI EN 1917

vista frontale
scala 1:20

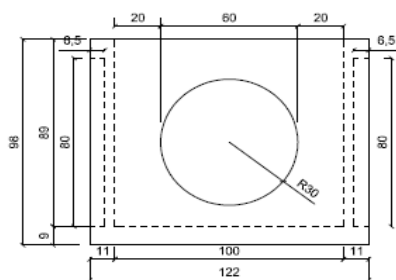

vista laterale
scala 1:20

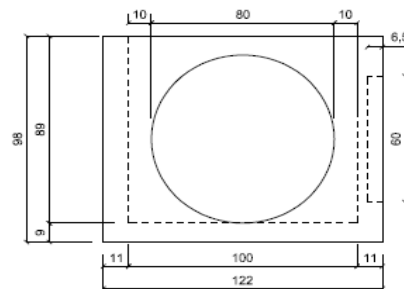

Pianta
scala 1:20

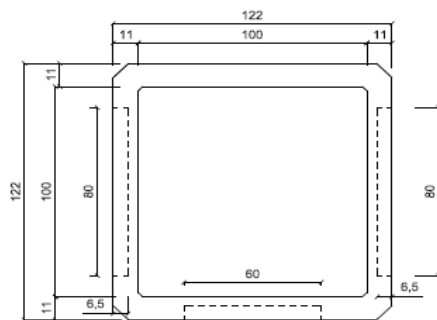

vista 3D

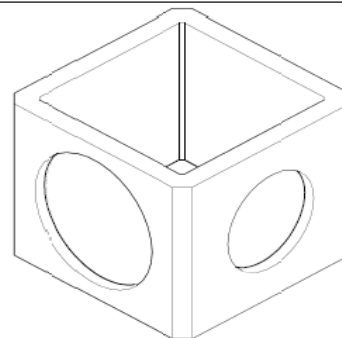

Cameretta con fondo
100x100

CARATTERISTICHE IMBALLO

QUANTITA' PER BANCALE

SFUSO

DATI TECNICI

PESO

KG

1250

CLASSE DI RESISTENZA CALCESTRUZZO

N/mm²

C32/40

SCHEDA N.

CAM100

DATA

29/12/20011

MOD. S823M

REVISIONE

N° 0 DEL 07/12/2020

F.LLI VACIS srl Via Dante Alighieri, 13 24050 COVO BG

Tel 036393167 Fax 0363938688

www.vacissrl.it - info: vacissrl@vacissrl.it