



F.LLI VACIS
G R O U P

SCHEMA TECNICA

POZZETTO PLUVIALE

POZZETTI IN CEMENTO VIBRATO



NORMA DI RIFERIMENTO UNI EN 1917:2004

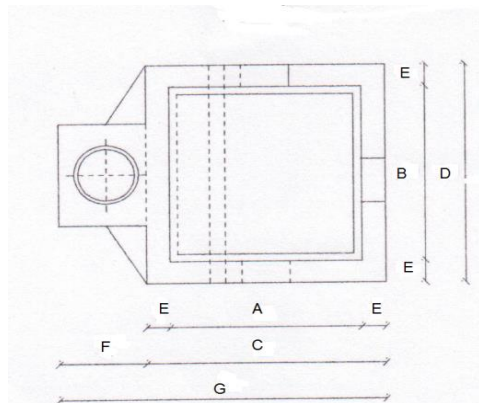

Pianta

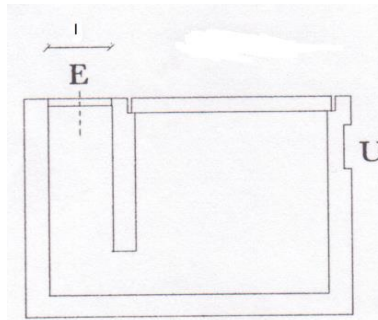

Sezione

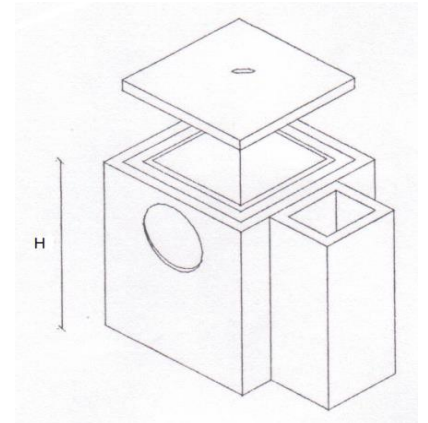

3D

DIMENSIONI

A	cm	15		H	cm	24		I	cm	10
B	cm	15		E	cm	3,5				
C	cm	22		F	cm	14				
DIMENSIONI	cm	22		G	cm	36				

CARATTERISTICHE IMBALLO

QUANTITA' PER BANCALE

30

DATI TECNICI

PESO

KG

20

CLASSE DI RESISTENZA CALCESTRUZZO

N/mm²

C32/40

SCHEDA N. POZPLU

DATA

05/04/2018

MOD. S823M

REVISIONE

N°1 DEL 07/12/2020

F.LLI VACIS srl Via Dante Alighieri, 13 24050 COVO BG

Tel 036393167 Fax 0363938688

www.vacisrl.it - info: vacisrl@vacisrl.it